

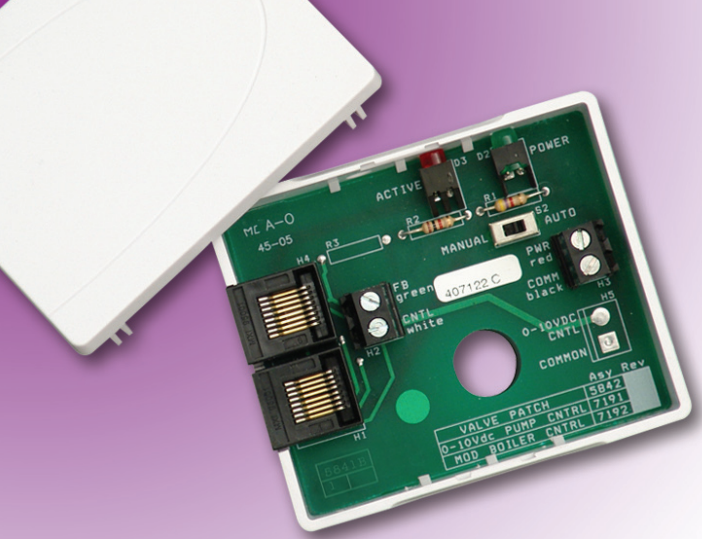

RADIANT HEATING SYSTEMS

**UPONOR CLIMATE
CÖNTRÖL™ NETWORK SYSTEM
MODULATING VALVE CONTROL**

INSTRUCTION SHEET



Modulating Valve Control, 0-10VDC

The Modulating Valve Control (A9063020) is used on any modulating valve and motor combination that is controlled by a 0-10VDC signal. This control is compatible with the following control systems:

- Uponor Climate Cönröl™ Multifunction Controller
- Climate Cönröl™ Network System

Uponor offers the Modulating Valve Control as a replacement part for three-way modulating valves. Uponor stocks these preassembled valves with controls as described in **Table 1**.

Part Number	Description
A9013021	3/4" Three-way Modulating Valve w/control, 0-10V (Cv=4.7)
A9013022	1" Three-way Modulating Valve w/control, 0-10V (Cv=10)
A9013023	1-1/4" Three-way Modulating Valve w/control, 0-10V (Cv=19)
A9013024	1-1/2" Three-way Modulating Valve w/control, 0-10V (Cv=29)

Table 1: Modulating Valve Control Assemblies

Note: This device can also be used to control two-way and four-way modulating valves.

Getting Started

Check the contents of this package. If the contents are damaged, please contact your Uponor sales representative or distributor for assistance.

The package includes:

- Modulating Valve Control, 0-10VDC (A9063020)

Tools and Parts Required

- RJ45 crimper and connectors
- Cable tester
- Wire cutter and stripper
- Small-blade screwdriver

Installation

Mounting the Unit

Mount the control to the conduit connection on the back of a Belimo valve (see **Figure 1**) or a separate electrical box using a standard 1/2-inch conduit hub (see **Figure 2**).



Figure 1: Belimo Valve Mounting



Figure 2: Electrical Box Mounting



Caution: Before performing any wiring, disconnect the electrical power to the system to prevent electrical shock and damage to the device.

Note: Ensure all wiring complies with local electrical codes.

Communication Cable

The Modulating Valve Control connects a modulating valve to an operating control via a single Cat5e cable. The Modulating Valve Control can be used on either of the Uponor control systems:

- **Climate Cönröl Multifunction Controller**
The Modulating Valve Control connects to any port on the right side of the Multifunction Controller that is assigned to it during setup.
- **Climate Cönröl Network System**
The Modulating Valve Control connects to Mix ports 1 thru 5 on the right side of the Supply Water Temperature Control (A9013000).

Sensors Connections

For the Network or Multifunction control systems to properly control water temperature, the Modulating Valve Control requires sensor information from the supply and return on the secondary piping. Connect the Dual Supply and Return Sensor (A9013001) to the Modulating Valve Control via a single RJ45-terminated Cat5e cable.



Important: The Modulating Valve Control comes with two modular ports, one that connects to the main control and the other that connects to the sensors. The Modulating Valve Control has a seamless design — there is no “wrong way” to connect the sensor or control.

Refer to Appendix D in the Uponor Climate Control Network System Manual for more information about making Cat5e patch cables.

Wiring the Modulating Valve Control

Use the following instructions to wire the Modulating Valve Control.

1. Squeeze the long sides of the cover to remove the cover from the valve.
2. Using 18-2 LVT wire or the wire supplied with the valve, make the following connections shown in **Table 2**.

Valve Wire	Control Terminal
Red	PWR
Black	COMM
Green	FB
White	CNTL

Table 2: Valve Wiring on Belimo LM24-SR Actuator

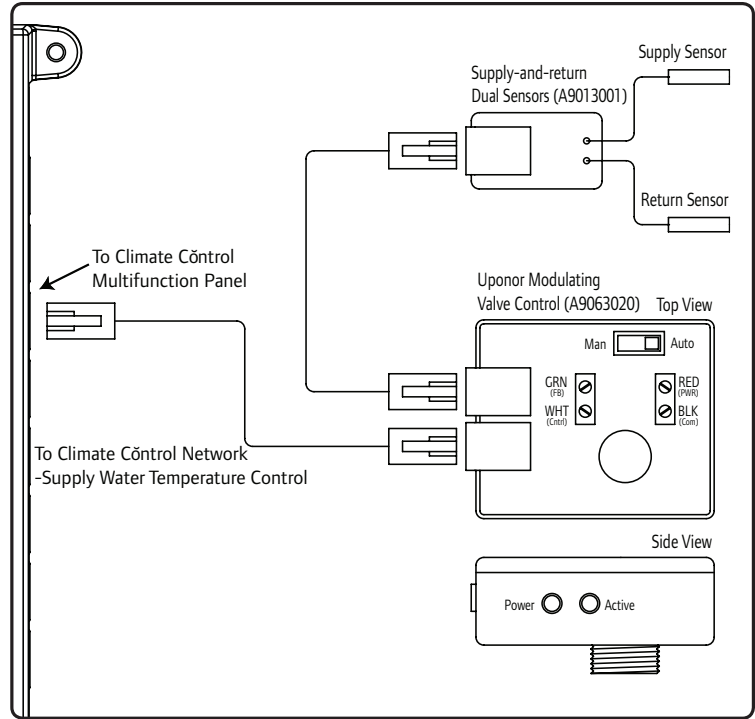

Figure 3: Wiring the Valve

Manual Switches

The Modulating Valve Control contains a manual switch inside the top cover. This switch can be used to override a control from changing the position of the valve. It can also be used to set the valve to a manual position. To change position of the valve manually, follow these steps.

- Move the switch to the MAN position.
- Press the black release button on the valve motor.

Note: Selecting the MAN position will fix the valve position until you return the selector switch to the AUTO position.

Indicators and Specifications

Indicator	Definition
Active	Illuminates to signal the valve is open at or above 25%
Power	Illuminates when the control receives power via the Cat5e cable from the Main Control Cabinet

Table 3: Indicator Definitions

Specifications

Storage Temperature:
14 to 160°F (-10 to 70°C)

Operating Temperature:
32 to 105°F (0 to 40°C)

% Relative Humidity:
10 to 90% non-condensing

Control Output:
0-10VDC 15 mA maximum

Power Output:
24VDC 15 mA maximum

Sensor Input: 10k NTC

Uponor, Inc.
5925 148th Street West
Apple Valley, MN 55124 USA
Phone: (800) 321-4739
Fax: (952) 891-2008
www.uponor-usa.com

Uponor Ltd.
655 Park Street
Regina, SK S4N 5N1 CANADA
Phone: (888) 994-7726
Fax: (800) 638-9517
www.uponor.ca

uponor